

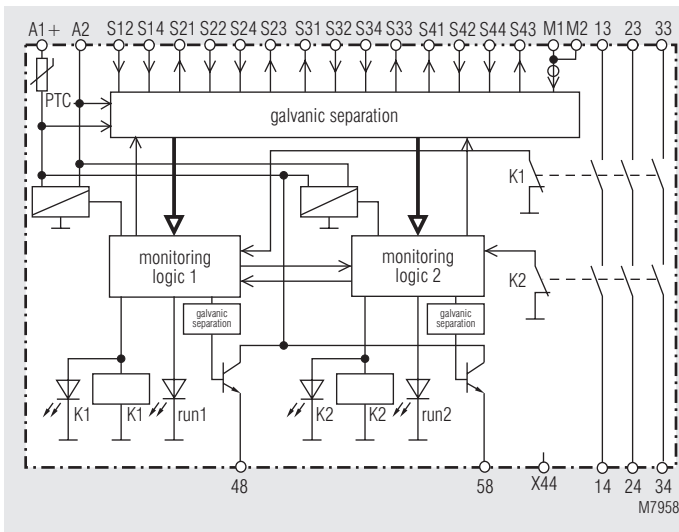

### Block Diagram



- According to
  - Performance Level (PL) e and category 4 to EN ISO 13849-1: 2008
  - SIL Claimed Level (SIL CL) 3 to IEC/EN 62061
  - Safety Integrity Level (SIL 3) to IEC/EN 61508
  - Category 4 to EN 954-1
- To connect max.:
  - 3 light curtains 2-channel or
  - 2 light curtains 2-channel and 2 muting sensors 1-channel or
  - 1 light curtain 2-channel and 4 muting sensors 1-channel or
  - 2 light curtains 2-channel and key switch for stepping operation
  - additionally: Start button and machine contact with line fault detection
- Broken wire detection on light curtain input
- Outputs:
  - 3 NO or 2 NO and 1 NC
  - 2 Semiconductor outputs, protected against short circuit and overload
- Multifunction device, different functions selectable by rotational switches:
  - protective operation e.g. light curtains
  - protective operation with muting, e.g. conveyors
    - \* signal sequence of muting sensors can be selected
    - \* override function via start button
  - Stepping operation e.g. on presses
    - \* optionally with key switch
    - \* 1, 2 or 3 steps possible
    - \* setting of number of step possible via selector switch
- Suitable to connect light curtains of type 4 or selftesting light curtains type 2 according to IEC/EN 61 496-1, crossfault monitoring in the light curtain
- With under- and overvoltage detection and indication
- Reaction time: max. 30 ms
- LED indication for RUN and Channel 1,2
- Width 45 mm

### Approvals and Markings



### Application

- Protection of men and machines e.g. presses and conveyors

### Indicators

lower green LEDs

K1, K2:

upper yellow LED

run 1:

- on, when K1 and K2 are energized
- permanent on, when relay K1 and K2 are energized
- flashes with 1 Hz when the unit waits for the start signal after fault free operation (power up of the unit)
- flashes fast with approx. 3 Hz when the start button is pressed and all conditions for an override are fulfilled during muting
- flashes fast with approx. 3 Hz when at stepping operation the unit waits for interruption of the light curtain
- flashes with failure code to indicate normal indication states that disable the energisation of the output relays (e.g. after not allowed interruption of the light curtain) until the start button is pressed
- flashes with failure code to indicate special failures (e.g. undervoltage)
- off, when unit is on special failure mode
- normally off when relays K1 and K2 are energized
- continuously on, when unit in muting mode
- shows the same failure codes as LED run 1 (except on special failures)

semiconductor output 48:

- off, when unit is on special failure mode
- normally off when relays K1 and K2 are energized
- continuously on, when unit in muting mode
- shows the same failure codes as LED run 1 (except on special failures)

## Indicators

- upper yellow LED run 2:
- permanent on, when unit operates correctly
  - flashes with failure code to indicate special operation failures (e.g. undervoltage)
- semiconductor output 58:
- off, when unit is on special failure mode
  - off, when relays K1 and K2 are energized
  - symmetric flashing, when a normal functional state is active that disables the energisation of the output relays (e.g. not allowed interruption of a light curtain)
  - permanent on, when waiting for start

## Notes

- On BH 5902.22 the NC contact 31-32 must only be used as monitoring contact
- Not suitable for machines where the area behind the light curtain is accessible
- Settings have to be carried out by educated personnel with disconnected power supply

## Operation Modes

### Protective operation (see Picture 1)

e.g. light curtains to secure dangerous areas

- Connection up to 3 light curtains
- Manual or automatic start possible for each light curtain
- With or without feedback input for external contactors

Possible settings:

		Switch 10: Start mode and feedback input									
		0	1	2	3	4	5	6	7	8	9
		without feedback input				with feedback input					
Switch 1	0	LC 1 Auto	LC 2 Manu	LC 3 Manu	Auto	Auto	Auto	Auto	Auto	Auto	Auto
	1	LC 1 Manu	LC 2 Manu	LC 3 Manu	Manu	Manu	Manu	Manu	Manu	Manu	Manu
					not allowed (fault 5)	Auto	Auto	Auto	Auto	Auto	Auto
						Manu	Manu	Manu	Manu	Manu	Manu
						Auto	Auto	Auto	Auto	Auto	Auto
						Manu	Manu	Manu	Manu	Manu	Manu
						Auto	Auto	Auto	Auto	Auto	Auto
						Manu	Manu	Manu	Manu	Manu	Manu
						Auto	Auto	Auto	Auto	Auto	Auto

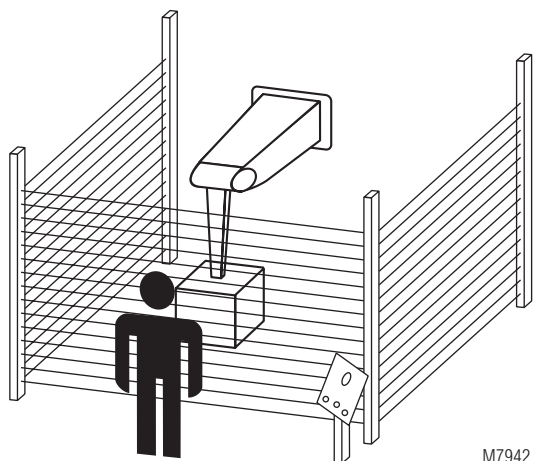

## Operation Modes

### Automatic start

On automatic start the contacts K1 and K2 are energized when the light curtain that is set for auto start is free after interruption. It is necessary that the other light curtains with manual start are not interrupted.

### Manual start

On manual start the contacts K1 and K2 are energized when the light barrier that is set for manual start is free after interruption and the start button is pressed ③

The start button must be activated in 2 conditions:

- after return of the supply voltage ① (when minimum 1 light curtain is programmed for manual start)
- when 1 light curtain with manual start was interrupted ③

## Function Diagram

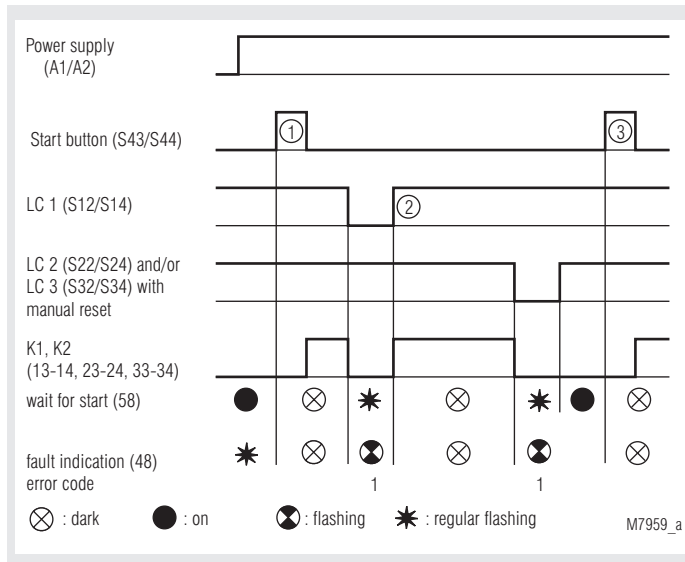

## Application Examples

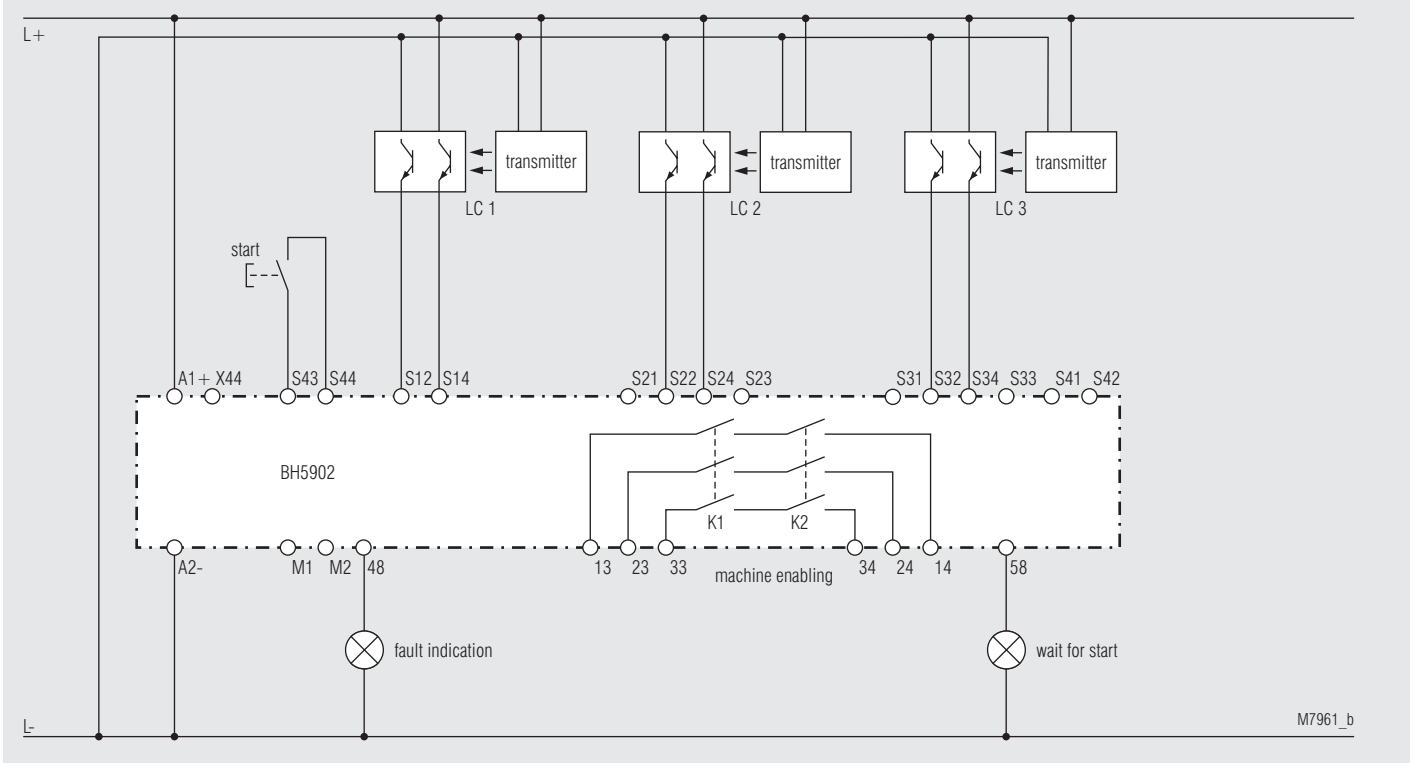

Picture 1: Protective operation with 3 LCs, manual or auto start, setting without feedback input

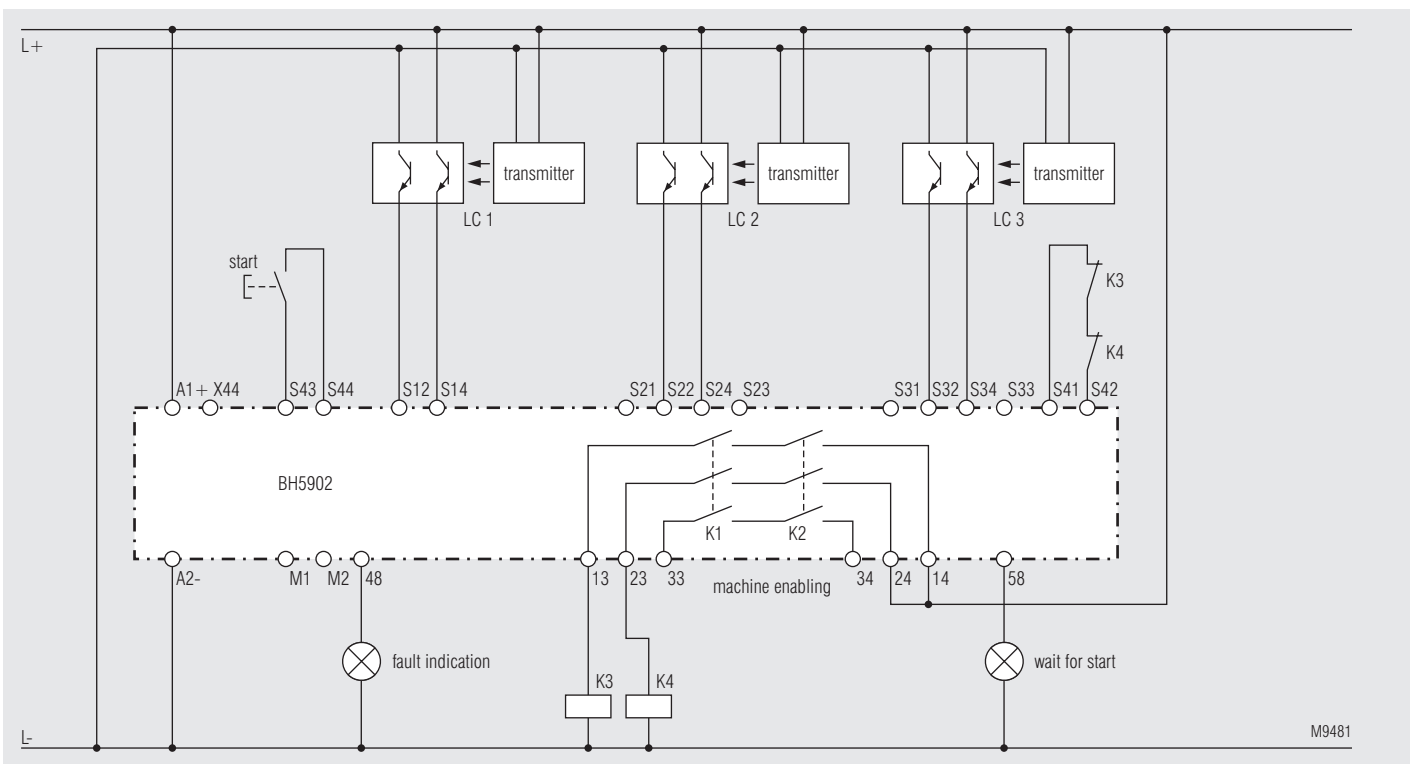

Picture 2: Protective operation with 3 LCs, manual or autostart, setting with feedback input

## Operation Modes

### Protective operation with muting

e.g. conveyors

- 1 or 2 light curtains
- Muting of light curtain 1
- 2 or 4 muting sensors with different input sequences
- LC1 with auto or manual start
- LC2 always with manual start
- Override via start button
- Manual start is always necessary after supply voltage is connected

### Muting

Muting means to disable temporarily the protective function of a light curtain. This function is used to transport material through a light curtain without stopping the machine. The differentiation between material and persons is done by additional muting sensors which have to create a certain switching sequence together with the light curtain when material passes the light curtain. The muting control starts then the muting cycle for the time the material is passing the light curtain. It must not be possible that a person activates the muting sensors in the same switching sequence as the material. To realise this function 2 different switching sequences can be chosen on BH 5902 either with 2 or 4 muting sensors. This makes sure that if a person passes the light curtain the dangerous movement of the machine is stopped immediately. The muting cycle is indicated by a muting lamp that is controlled and monitored by the BH 5902. The maximum muting time can be set in 10 steps between 10 s and infinite.

If the light curtain is still interrupted after the max. permitted muting time e.g. by blocked material the contacts K1, K2 open and the muting lamp as well as the LED run 1 show failure code 4.

Starting by pressing the start button is only possible if the muting lamp is working and the light curtain to be muted is free of interruption. During the muting cycle a wrong switching sequence or exceeding the maximum muting time leads to failure code 4. This failure can only be reset by pressing the start button. The muting sensors have to be installed in a way, that the correct sequence cannot be achieved manually or by passing the light curtain (see IEC/EN 61 491-1)

Possible settings:

		Switch 10: a = maximum muting time b = maximum synchronising time										
		0	1	2	3	4	5	6	7	8	9	
Switch 1	2	LC S1 Auto, muting 2 sensors	a: 10 s / b: 3 s	a: 20 s / b: 3 s	a: 30 s / b: 3 s	a: 1 min / b: 6 s	a: 5 min / b: 30 s	a: 15 min / b: 90 s	a: 30 min / b: 3 min	a: 1 h / b: 3 min	a: 8 h / b: 3 min	no muting time monitoring
	3	LC S1 Manu, muting 2 sensors										
	4	LC S1 Auto, muting 4 sensors										
	5	LC S1 Manu, Muting 4 sensors										

### Override

If the monitored area is blocked by transported material and the outputs K1, K2 are switched off, this is indicated by fast flashing (approx. 3 Hz) of the muting lamp. The operator can activate the outputs K1, K2 by pressing the start button for more than 3 s for a maximum time of 12 s until the muting sensor are again inactive or the start button is released again.

Example for an override cycle when muting with 2 sensors

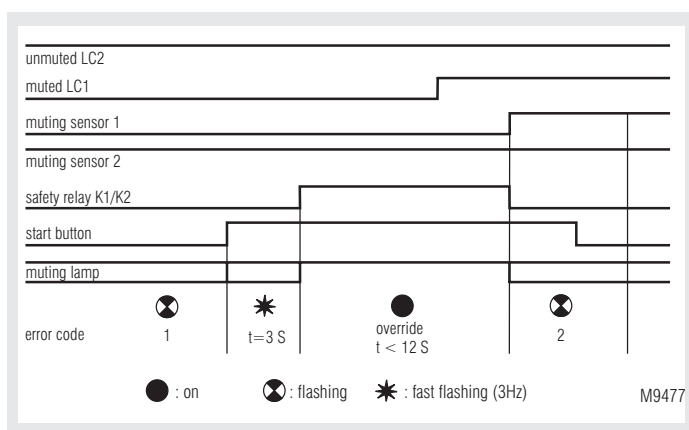

In all function diagrams the part "monitored operation" is the phase where the unit differentiates between men and material.

### Using 2 muting sensors

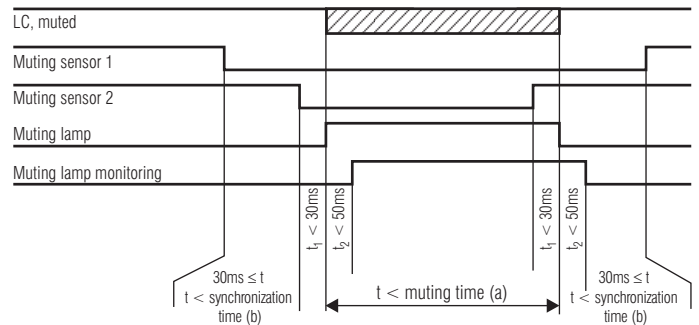
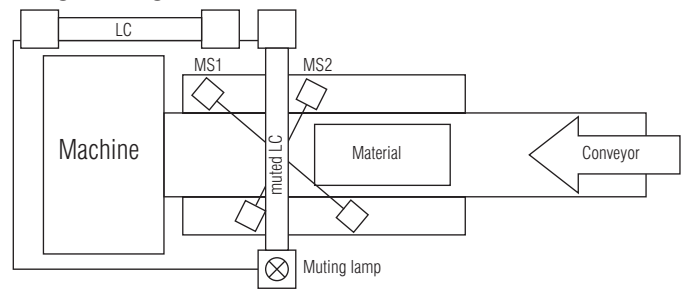

M7962\_a

### Using 4 muting sensors

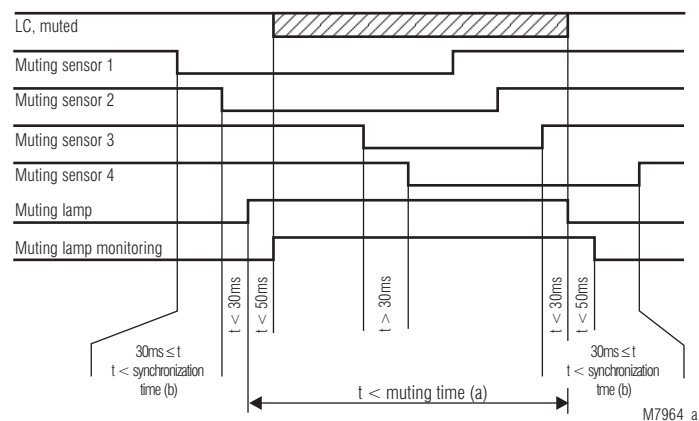
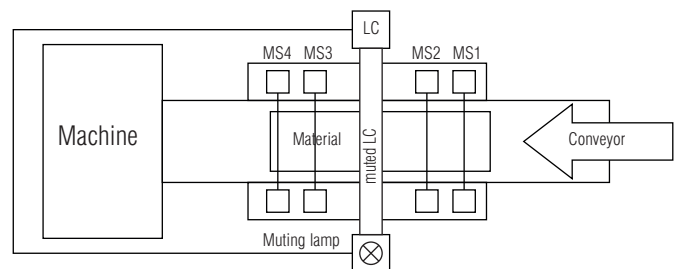

M7964\_a

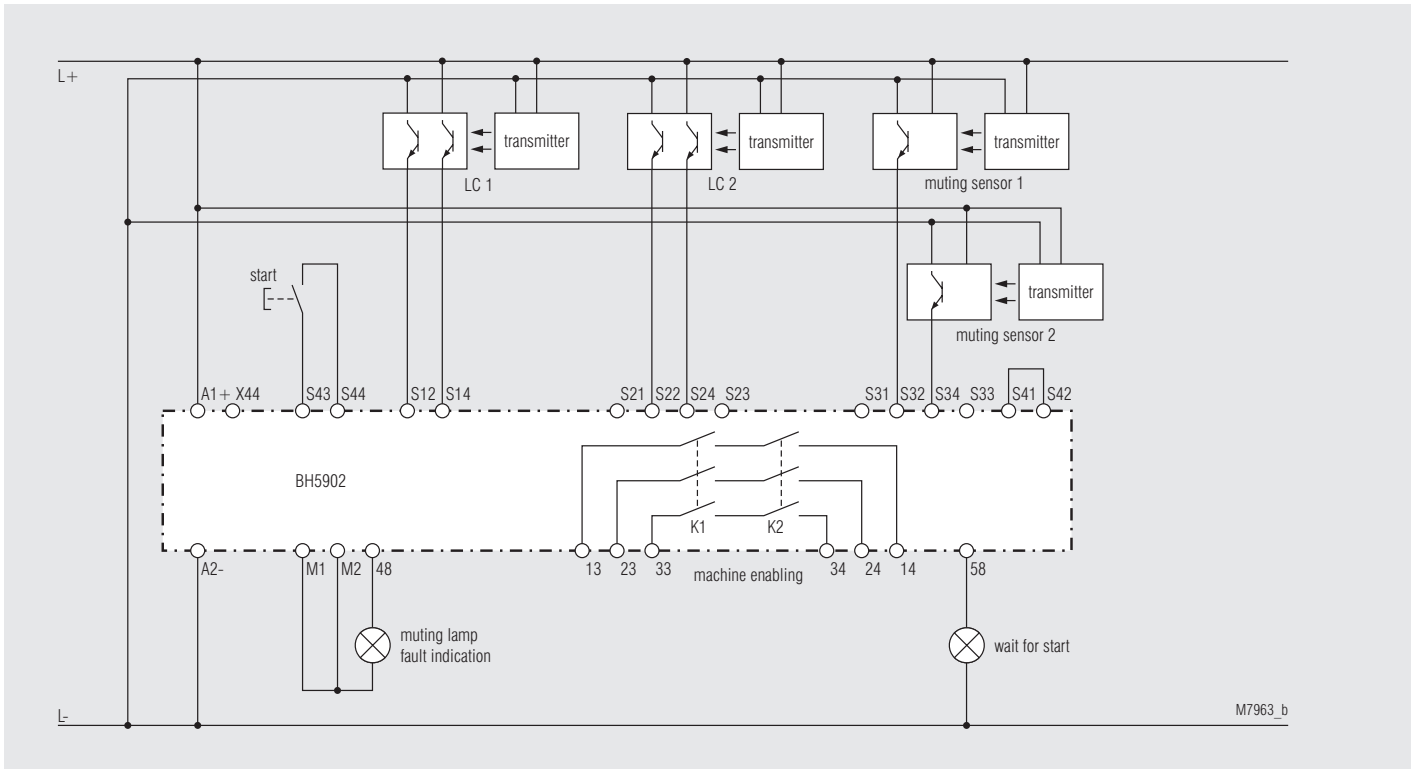

Picture 3: Protective operation with muting a light curtain via 2 muting sensors, 2 light curtains

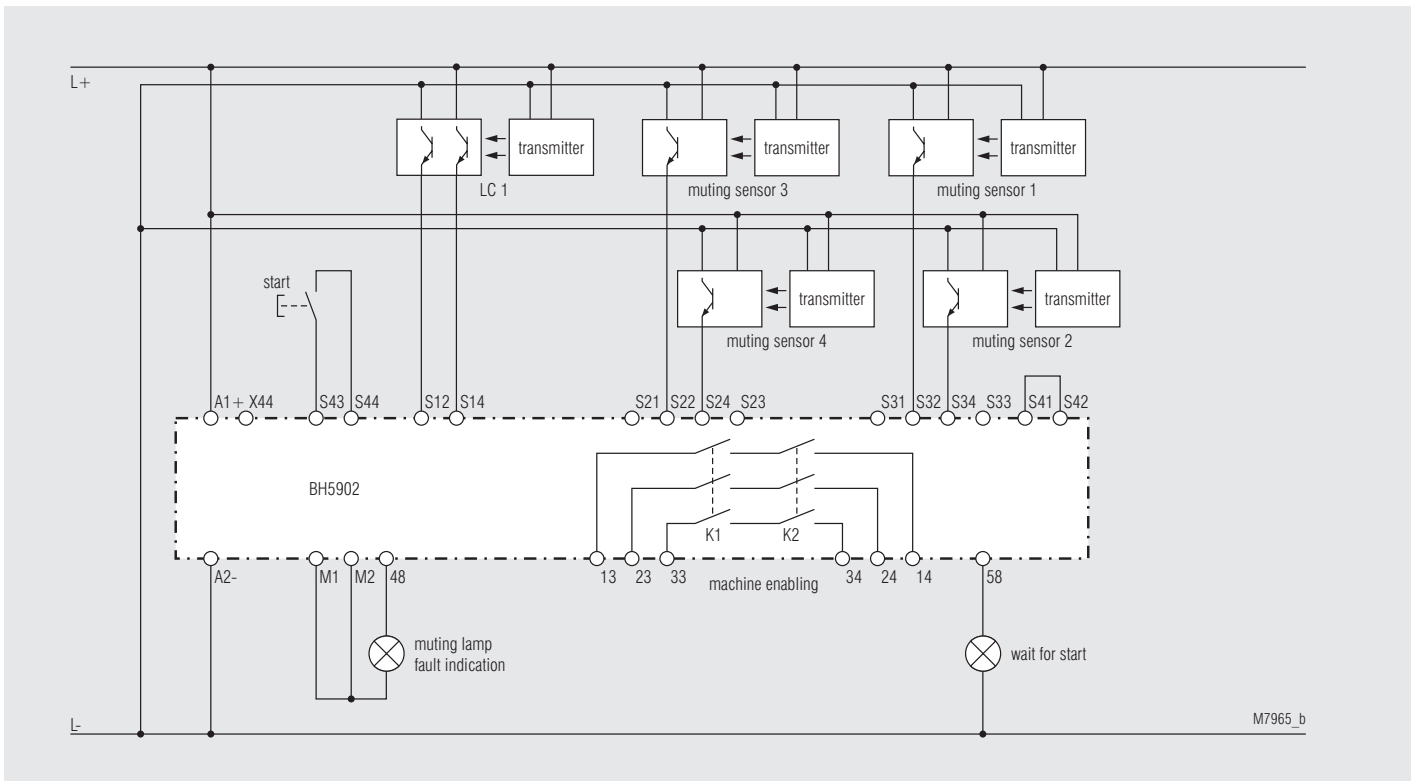

Picture 4: Protective operation with muting, 1 light curtain, 4 muting sensors

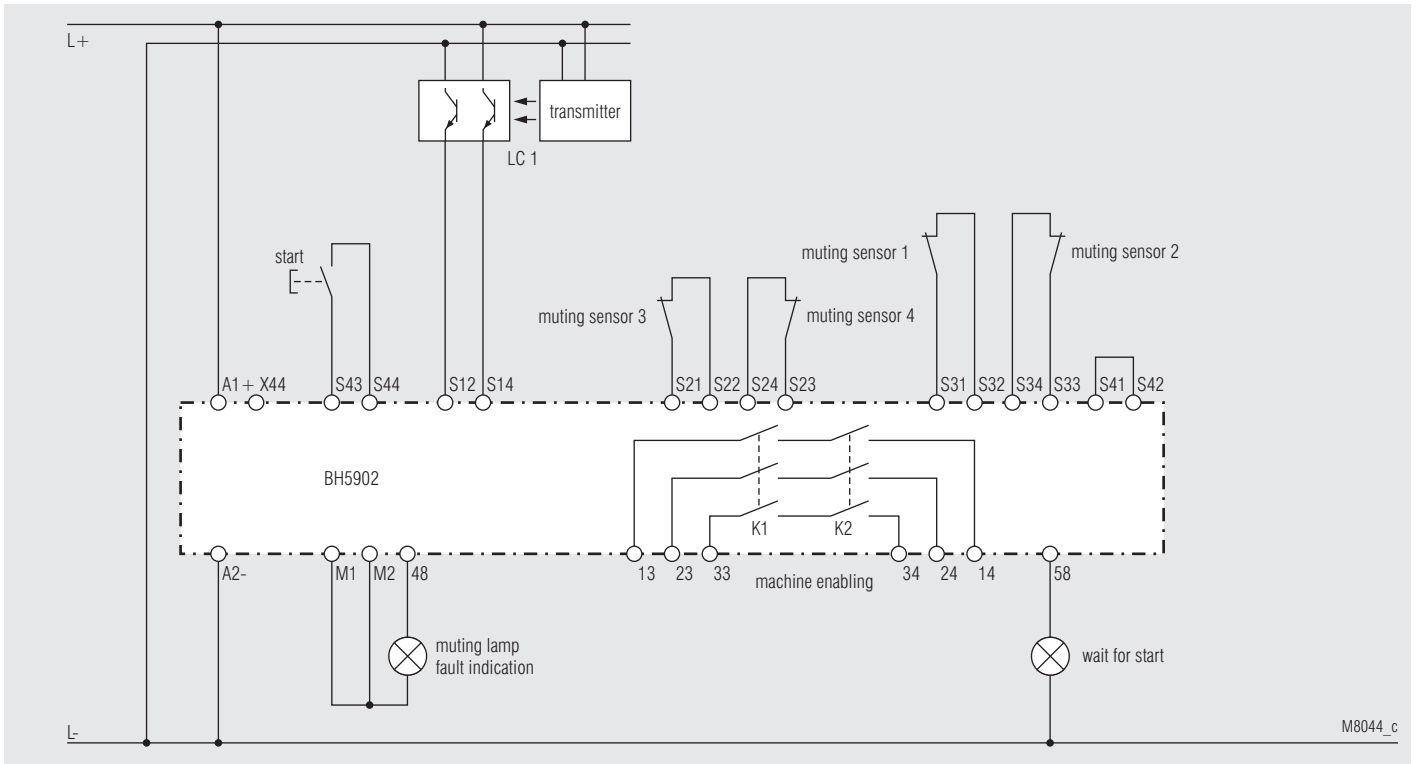

Picture 5: Protective operation with muting via 4 muting sensor contacts

**Contact reinforcement**

If external relays or contactors are used to reinforce or multiply the contacts of the safety relays these must be monitored by feeding back one NC contact of each relay/contactactor into the start circuit (see application example picture 8).

## Operation Modes

### Stepping operation

e.g. Presses with manual operation and automatic start

- Max. 3 light curtains
- LC2 and LC3 always with manual start

Setting functions:

- 1, 2 or 3 steps
- 2 different start sequences
- 2 ways of monitoring the machine contact
- Number of steps fixed or settable with key switch

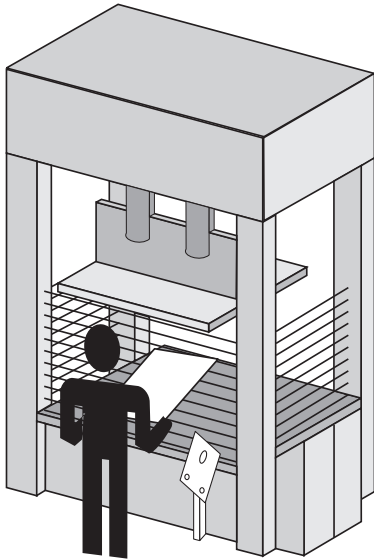

M7955

Stepping operation enables automatic restart of a machine (Press) after a certain number of accesses into the protected area of the first LC. This Operation consists of start sequence and normal sequence.

Possible settings

		Switch 10: Number of steps				
		0	1	2	3	4 - 9
Switch 1	6	selectable by key switch	1 step	2 step	3 step	not allowed (fault 5)
	7					
	8					
	9					

### Start sequence

To enable the machine at start-up on stepping operation 2 different start sequences can be chosen:

- 1.) The required number of interruptions of the LC must be completed and then the start button must be pressed.
- 2.) The start button is pressed first, and after that the required number of interruptions must be completed.

The request to start the operation (e.g. 2 steps according to the diagrams below) is signalled by a flashing lamp (terminal 48). The request to press the start button is signalled by continuous light on a lamp (terminal 58). After finishing the starting sequence correctly the lamps go off and the contact K1 and K2 close.

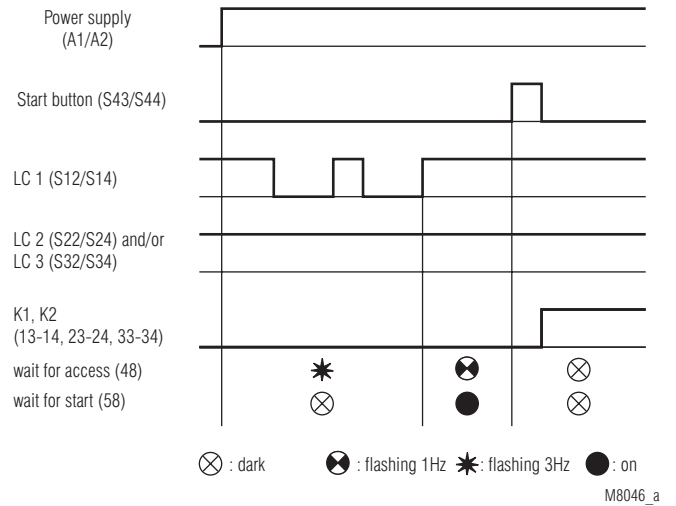

### Start sequence: 2 steps and start button

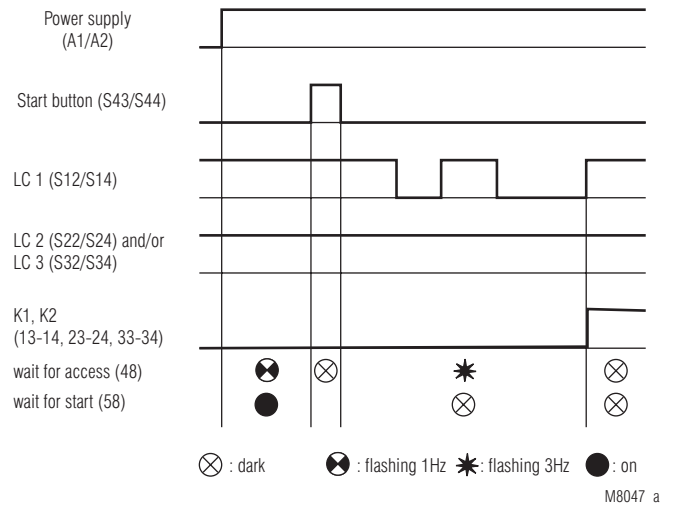

### Start sequence: start button and 2 steps

## Operation Modes

### Normal sequence

A correct starting sequence is necessary to run the normal operating sequence. In the normal operating sequence the machine movement is signalled to the light curtain by opening and closing of the machine contact. The output contacts of the BH 5902 are opened when the machine contact opens. After that the operator must interrupt the LC for the required number of times to start again the machine operation. All necessary steps must be completed within 30 s. The demand to access is indicated on fast flashing (3 Hz) output 48. When the required number of interruptions on the LC is completed the lamp goes off and the contacts K1 and K2 close.

### Machine contact

To the terminals S41 and S42 of the BH 5902 a machine contact must be connected. It opens and closes depending on the machine movement.

### Monitoring of the machine contact

2 ways of monitoring are selectable:

#### Mode 1

In this mode the access to the LC must only be done when the machine contact has been opened and closed again. An exception is when the access is done while the contact is open and still is going on while the contact closes.

#### Mode 2

In this mode the accesses are accepted already when the machine contact

The lamp on terminal 48 flashes with code 1. After finishing the access the lamp on terminal 58 returns to permanent light and signalises, that the machine can be started with the start button.

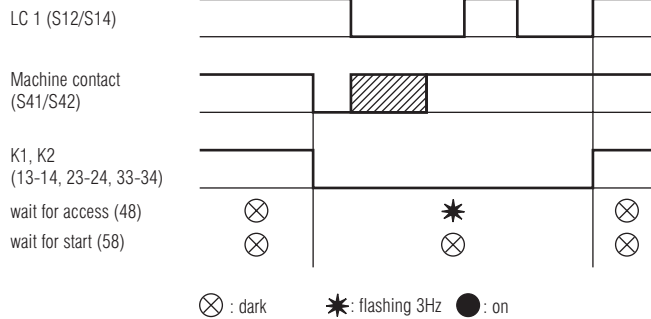
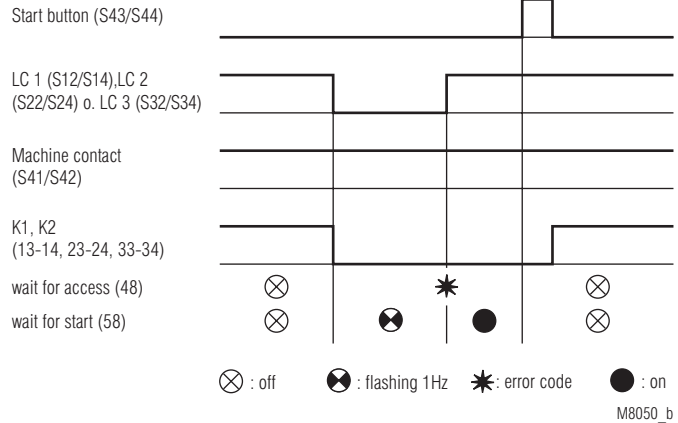

Application: Presses with normal to fast movement

is open. The machine is only enabled when all the accesses are completed and the machine contact is closed again.

### Forbidden access into the light curtain

On forbidden access the lamp (on terminal 58) shows symmetric flashing.

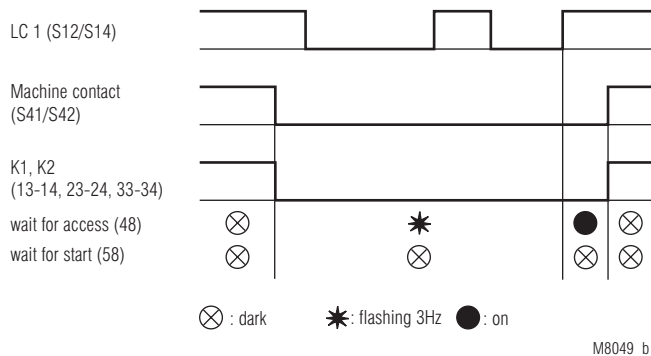

Application: Presses with slow movement



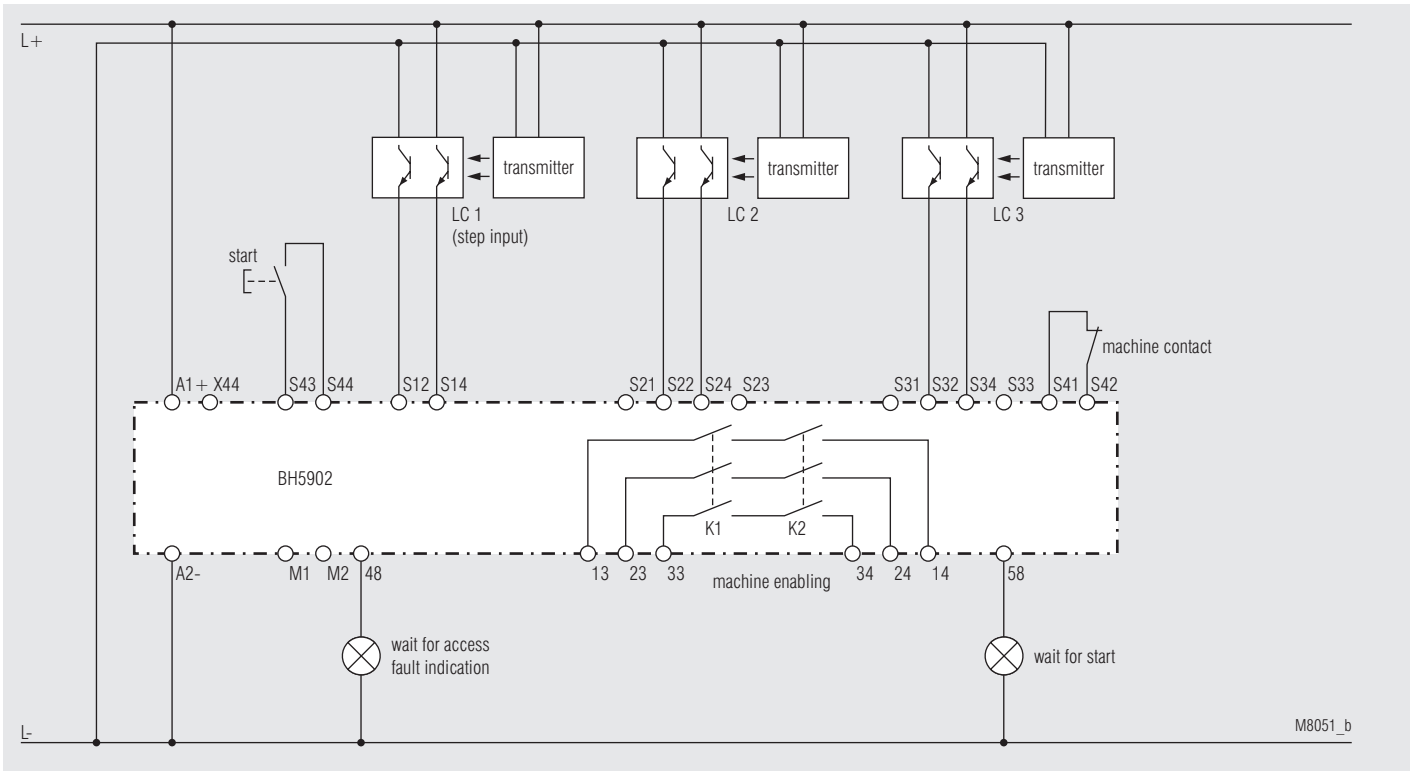

Picture 6: Stepping operation with 3 light curtains

**Stepping operation with key switch**

e.g. Presses witch changing number of accesses

- selection iwth key switch: 1, 2 or 3 steps

**Enable new setting**

A changed number of steps is only recognised at standstill (K1 and K2 open).

A new number of steps is signalled by failure indication 3 on the lamp (terminal 48). Pressing the start button will restart the unit. After that the normal start sequence complete swith start button and number of accesses must be completed to enable the machine with the new number of steps.

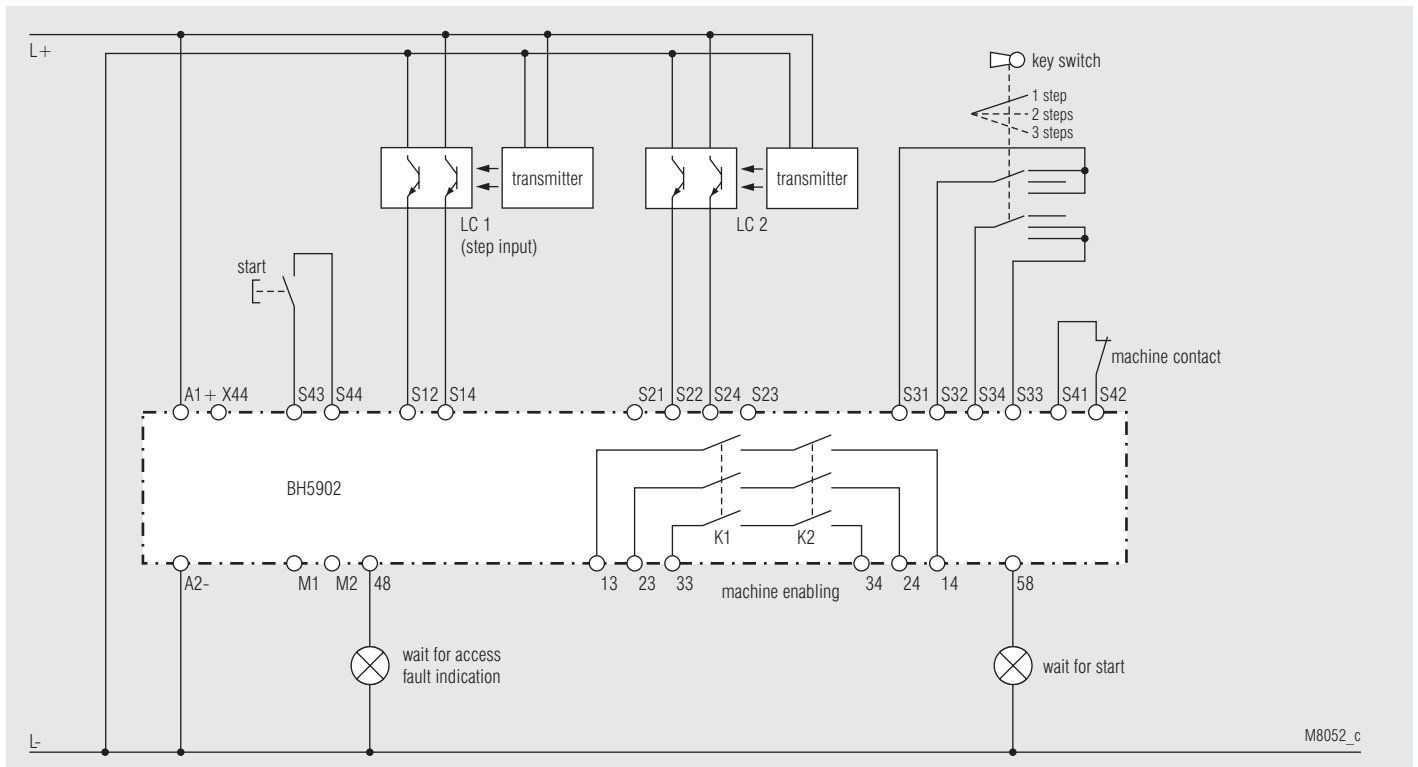

Picture 7: Stepping operation with key switch

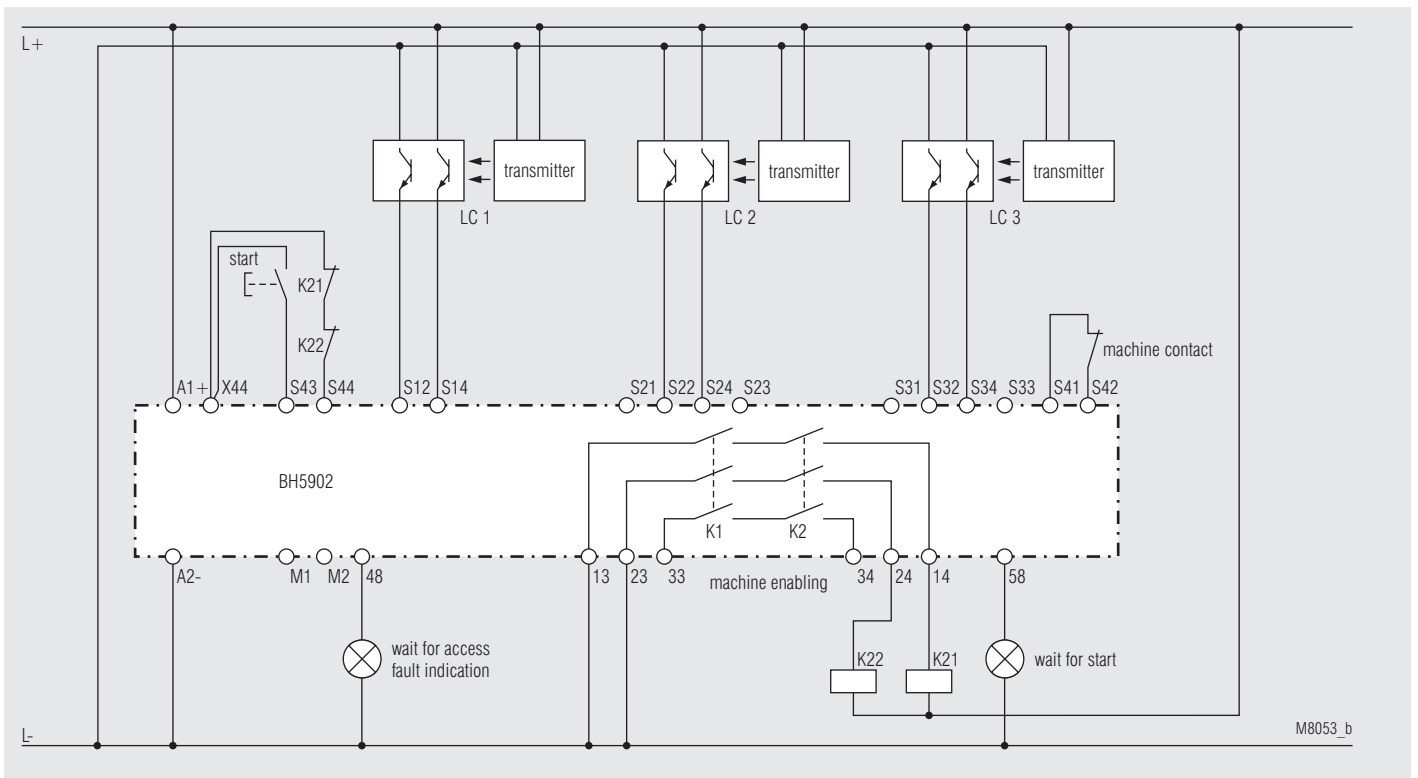

Picture 8: Stepping operation with 3 light curtains and contact reinforcement by external contactors, 2-channel operation (switching of feedback input can also be used at protective operation with muting)

The feed back circuit of the external relays is only tested when the module is started by pressing the push button. When using this circuit the safe function has to be tested in regular intervals. This can be done by interrupting a light curtain so that a reset requires activation of the start button. activating the module is only possible when all external relays are de-energized.

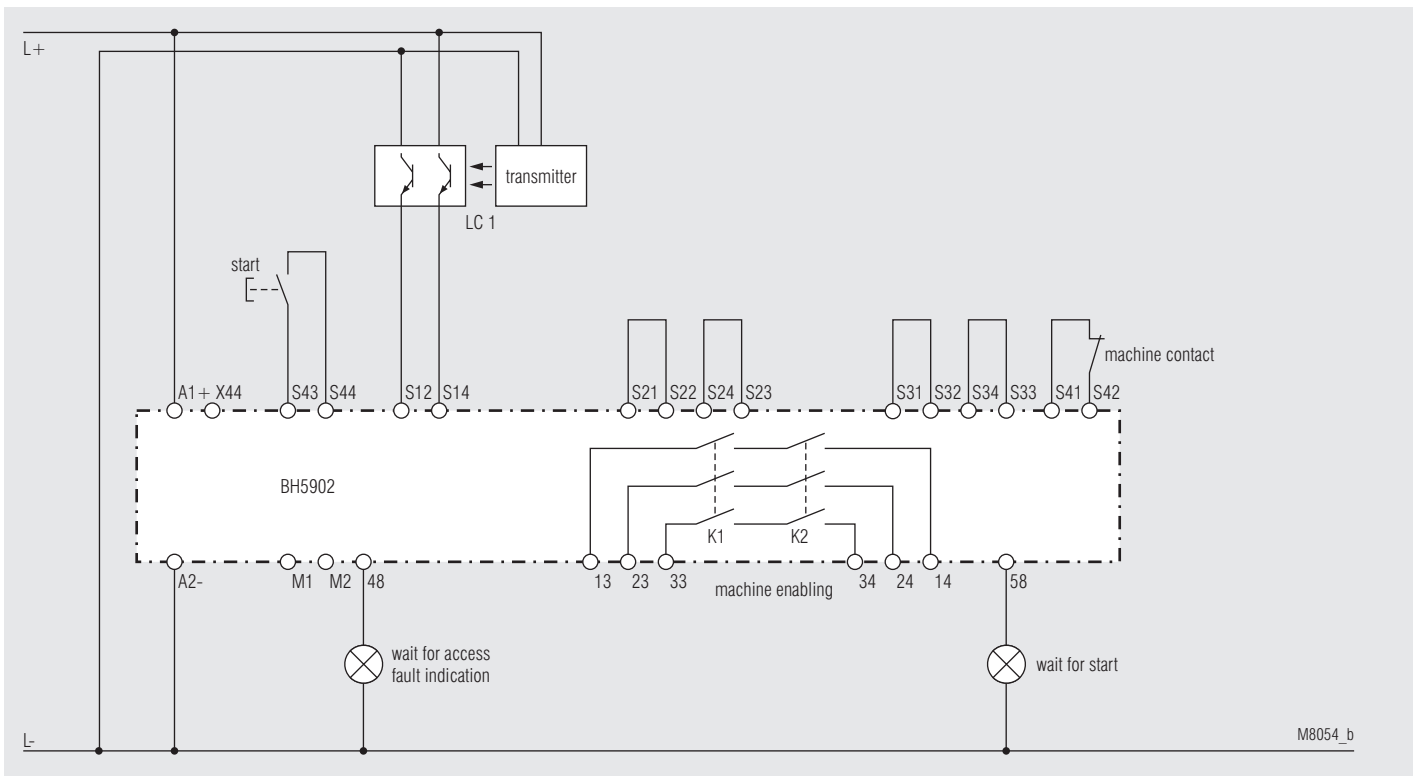

Picture 9: Stepping operation with one light curtain (with all different operating modes unused inputs must be linked).

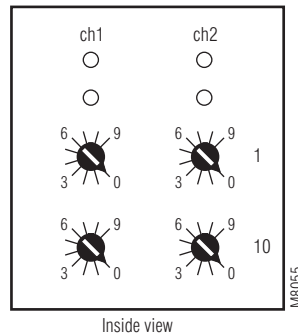
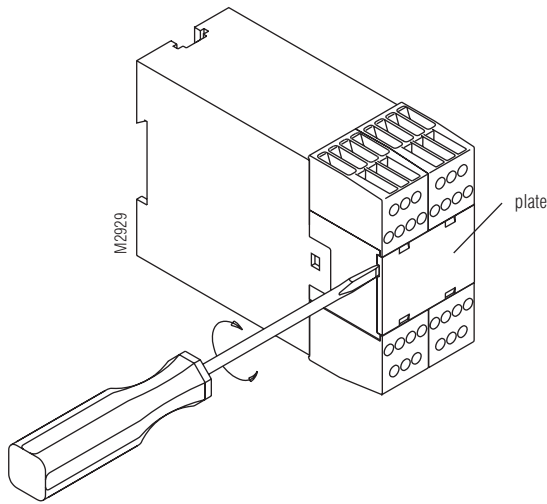

**Example:**

Required function: Protective operation with manual start, with muting, 4 muting sensors, max. 30 s muting time.

Setting:

Upper switches set to "5" for both  $\mu$ processors  
 Lower switches set to "2" for both  $\mu$ processors

The function setting of BH 5902 is made by 4 rotational switches behind the frontplate (see picture). The switches on the left make the setting for  $\mu$ processor 1 (LED run 1) and the switches on the right for  $\mu$ processor (LED run 2). For both processors the same functions must be set. On the upper switches (1) the main function is adjusted. On the lower switches (10) the setting of the muting time (Protective operation) or the number of steps (stepping operation) is adjustable.

On muting or stepping function the light curtains LC 2 and LC 3 are always in protective operation with manual start.

**Protective operation without muting**

		Switch 10: Start mode and feedback input									
		0	1	2	3	4	5	6	7	8	9
		without feedback input			with feedback input						
Switch 1	0	LC 1 Auto	LC 2 Manu	LC 3 Manu	Auto	Auto	Auto	Manu	Manu	Manu	not allowed (fault 5)
	1	LC 1 Manu	LC 2 Manu	LC 3 Manu	Manu	Auto	Auto	Manu	Manu	Manu	

**Protective operation with muting**

		Switch 10: a = maximum muting time b = maximum synchronising time											
		0	1	2	3	4	5	6	7	8	9		
Switch 1	2	LC S1 Auto, muting 2 sensors		a: 10 s / b: 3 s	a: 20 s / b: 3 s	a: 30 s / b: 3 s	a: 1 min / b: 6 s	a: 5 min / b: 30 s	a: 15 min / b: 90 s	a: 30 min / b: 3 min	a: 1 h / b: 3 min	a: 8 h / b: 3 min	no muting time monitoring
	3	LC S1 Manu, muting 2 sensors											
	4	LC S1 Auto, muting 4 sensors											
	5	LC S1 Manu, muting 4 sensors											

**Stepping operation**

		Switch 10: Number of steps						
		0	1	2	3	4 - 9		
Switch 1	6	Stepping operation, contact type 1, Start-sequence: stepping and start		selectable by key switch	1 step	2 step	3 step	not allowed (fault 5)
	7	Stepping operation, contact type 2, Start-sequence: stepping and start						
	8	Stepping operation, contact type 1, Start-sequence: start and stepping						
	9	Stepping operation, contact type 2, Start-sequence: start and stepping						

## Circuit Diagramms

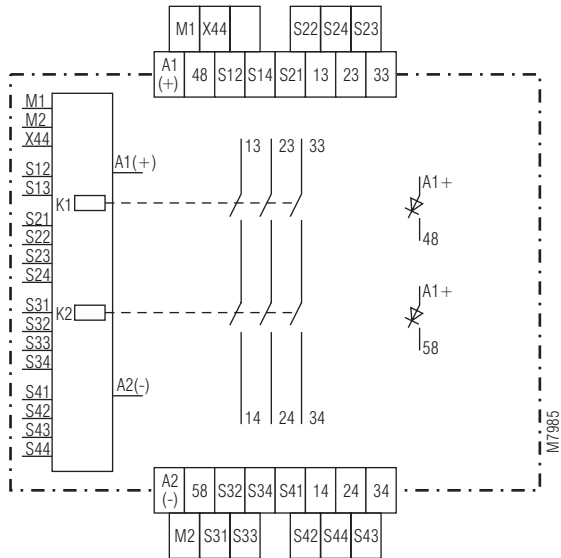

BH 5902.03

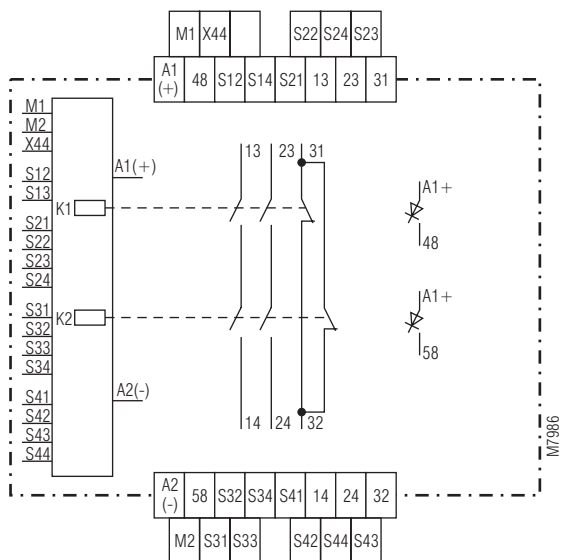

BH 5902.22

## Characteristic

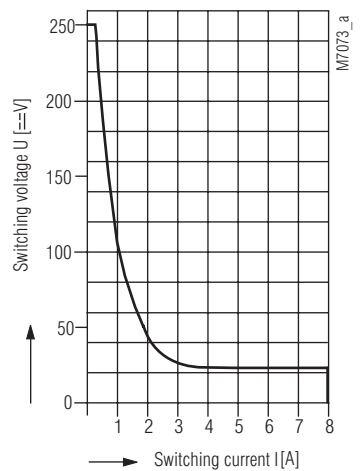

safe breaking, no continuous arcing  
under the curve, max. 1 switching cycle/s

Lichtbogengrenzkurve

## Technical Data

### Input

<b>Nominal voltage <math>U_N</math>:</b>	DC 24 V
<b>Voltage range:</b>	
at max. 5 % residual ripple:	0,85 ... 1,15 $U_N$
<b>Nominal consumption:</b>	max. 170 mA (no load on semiconductor outputs)
<b>Control voltage on S21, S23, S31, S33, S41, S43, S48, S58:</b>	DC 23 V at $U_N$
<b>Control current on S12, S14, S22, S24, S32, S34, S42, S44:</b>	each 4,5 mA at $U_N$
<b>Min. voltage on terminals S12, S14, S22, S24, S32, S34, S42, S44:</b>	DC 16 V
<b>Short circuit protection:</b>	internal with PTC
<b>Min. current on M1, M2:</b>	25 mA with active lamp

### Output

<b>Contacts</b>	
BH 5902.03:	3 NO contacts
BH 5902.22:	2 NO, 1 NC contacts The NC contact must only be used as monitoring contact ! Relay, forcibly guided
<b>Contact type:</b>	
<b>Operate delay typ. at <math>U_N</math>:</b>	
Manual start:	max. 50 ms
Automatic start:	max. 1,5 s
Automatic restart:	max. 55 ms
<b>Release delay (reaction time):</b>	max. 30 ms (max. 50 ms when failure on LC and only one input channel de-energises)
<b>Output voltage:</b>	AC 250 V DC: see Limit curve for arc-free operation $\geq 100$ mV

<b>Thermal current <math>I_{th}</math>:</b>	5 A
<b>Switching capacity</b>	
to AC 15:	
NO contact:	3 A / AC 230 V IEC/EN 60 947-5-1
NC contact	2 A / AC 230 V IEC/EN 60 947-5-1
to DC 13 at 0,1 Hz:	8 A / DC 24 V IEC/EN 60 947-5-1
<b>Electrical life</b>	
to AC 15 at 2 A, AC 230 V:	$10^5$ switching cycles IEC/EN 60 947-5-1
<b>Permissible switching frequency:</b>	max. 1 200 switching cycles / h
<b>Short circuit strength</b>	
max. fuse rating:	6 A gL IEC/EN 60 947-5-1
line circuit breaker:	C 8 A
<b>Mechanical life:</b>	$10 \times 10^6$ switching cycles

### Semiconductor Outputs

Output (terminal 48 and 58):	Transistors, plus-switching
Output voltage:	DC 24 V, max. 100 mA continuous current, max. 400 mA for 0,5 s internal short circuit, overtemperature and overload protection

### General Data

<b>Operating mode:</b>	Continuous operation
<b>Temperature range</b>	
operation:	$\pm 0$ ... + 50 °C
storage :	- 25 ... + 85 °C
<b>altitude:</b>	< 2.000 m
<b>Clearance and creepage distances</b>	
rated impulse voltage / pollution degree:	4 kV / 2 (basis insulation) IEC 60664-1
<b>EMC</b>	
Electrostatic discharge:	8 kV (air) IEC/EN 61 000-4-2 (according to test degree 3)
HF irradiation:	10 V / m IEC/EN 61 000-4-3
Fast transients:	
on wires for power supply A1-A2:	2 kV IEC/EN 61 000-4-4
on wires for signals and control:	2 kV IEC/EN 61 000-4-4

## Technical Data

Surge voltages between wires for power supply:	1 kV	IEC/EN 61 000-4-5
between wire and ground:	2 kV	IEC/EN 61 000-4-5
HF wire guided:	10 V	IEC/EN 61 000-4-6
Interference suppression:	Limit value class B	EN 55 011
<b>Degree of protection:</b>	according to IEC/EN 61 496-1 (1997)	the unit has to be installed in a housing with protection degree 54.
Housing:	IP 40	IEC/EN 60 529
Terminals:	IP 20	IEC/EN 60 529
<b>Housing:</b>	Thermoplastic with V0 behaviour	according to UL subject 94
<b>Vibration resistance:</b>	according to IEC/EN 61 496-1 (1997)	Amplitude 0,35 mm IEC/EN 60 068-2-6 frequency 10 ... 55 Hz
<b>Shock resistance:</b>	Acceleration: 10 g	
	Impulse length: 16 ms	
	Number of shocks: 1000 per axis on 3 axis	
<b>Climate resistance:</b>	0 / 050 / 04 IEC/EN 60 068-1	
<b>Terminal designation:</b>	EN 50 005	
<b>Wire connection:</b>	1 x 2,5 mm <sup>2</sup> stranded ferruled or 1 x 4 mm <sup>2</sup> solid or 2 x 1,5 mm <sup>2</sup> stranded ferruled	DIN 46 228-1/-2/-3/-4
<b>Wire fixing:</b>	Terminal screws M 3,5	Box terminal with wire protection
<b>Mounting:</b>	DIN rail	IEC/EN 60 715
<b>Weight:</b>	320 g	

## Dimensions

**Width x height x depth:** 45 x 84 x 121 mm

## Safety Related Data

### Values according to EN ISO 13849-1:

Category:	4	
MTTF <sub>d</sub> :	31.5	a
DC / DC <sub>avg</sub> :	98.9	%
d <sub>op</sub> :	220	d/a (days/year)
h <sub>op</sub> :	12	h/d (hours/day)
t <sub>Zyklus</sub> :	144	s/Zyklus

### Values according to IEC/EN 62061 / IEC/EN 61508:

SIL CL:	3	IEC/EN 62061
SIL	3	IEC/EN 61508
HFT:	1	
DC / DC <sub>avg</sub> :	98.9	%
SFF	99.6	%
PFH <sub>D</sub> :	7.80E-09	h <sup>-1</sup>

<sup>1)</sup> HFT = Hardware-Failure Tolerance



The values stated above are valid for the standard type.

Safety data for other variants are available on request.

The safety relevant data of the complete system has to be determined by the manufacturer of the system.

## UL-Data

The safety functions were not evaluated by UL. Listing is accomplished according to requirements of Standard UL 508, "general use applications"

<b>Nominal voltage U<sub>N</sub>:</b>	DC 24 V
<b>Ambient temperature:</b>	0 ... +50°C
<b>Switching capacity:</b>	
Ambient temperature 50°C:	Pilot duty B300 5A 250Vac G.P. 5A 24Vdc
Semiconductor outputs:	24Vdc, 100 mA
<b>Wire connection:</b>	60°C / 75°C copper conductors only AWG 20 - 12 Sol Torque 0.8 Nm AWG 20 - 14 Str Torque 0.8 Nm



Technical data that is not stated in the UL-Data, can be found in the technical data section.

## Standard Type

BH 5902.03/01MF2/61 DC 24 V

Article number: 0053847

- Output: 3 NO contacts
- all functions settable via rotational switches
- Nominal voltage U<sub>N</sub>: DC 24 V
- Width: 45 mm

## Ordering Example

BH 5902 . . . /01MF2/61 DC 24 V



## Flashing Codes For Status And Failure Indication

When a failure is detected the relays K1, K2 are de-energized. The different failures are indicated by different flashing codes on the LEDs run 1 and run 2. The failures are split into 2 groups.

Failure group 1:

### System failure

On occurrence of such a failure the unit locks out and shows the failure code, the module can only be reset by switching the unit off and on again. These failures are only indicated on LEDs run 1 and/or run 2. At the same time 2 different codes can be indicated on the 2 LEDs. The outputs (48 and 58) are always off in this state.

Failure group 2:

### Function failure

These failure codes are only displayed on LED run 1 and output 48 while LED run 2 remains on permanently. The relays K1, K2 are de-energized in this state, the module is still active and the relays can be activated by pressing the start button after the failure has been removed.

**System failure:** (indicated only on LEDs run 1 and/or run 2)

No.*)	Description	Measures and notes
0	internal failure (LEDs off)	If both LEDs are off the relay is defective and has to be sent back for examination.
5	Faulty setting	1) The switches on both channels are not identically 2) The selected setting is not allowed.
6	Undervoltage detection	Left LED is flashing when the voltage drops under the allowed level (< approx. 0.85 UN). After returned to normal a reset is made (similar to power up of the unit).
6	Overvoltage detection	The right LED is flashing when the voltage rises over the allowed level of > approx. 1,15 UN + 5 % residual ripple.
7	Input failure	1) A short circuit occurred on the start button or machine contact input.2) 2) Both signals of one LC are not identically (short circuit, broken wire of defective LC)
8	Failure on output contacts K1, K2	Please check the output K1, K2 circuit and contact current, relay has to be repaired.
9	Internal failure	Please try to evaluate the circumstances that led to this fault and check with the supplier or manufacturer.
10		
11	Internal failure	The relay has to be repaired.
12		
13		

\*) No.: number of flash pulses in a series

## Flashing Codes For Status And Failure Indication

**Function failure:** indication on LED run 1 and output 48

No.*)	Description	Measures and notes
1	LC failure	1) One LC has been interrupted. 2) All LC inputs that are not used must be bridged: LC 2: S21-S22, S23-S24 LC 3: S31-S32, S33-S34
2	Failure on start button	1) During start up of the unit and initialising the start button must not be pressed 2) The start button must not be pressed longer than 3 s.
3	Protective operation failure in feed back circuit	1) An operating mode with feed back circuit ist selected and and the circuit connected to S41-S42 is not closed before activation of K1, K2.
3	Stepping operation contact failure	1) The machine contact is not closed in initial position (waiting for start) 2) With contact type 1 the machine contact was not closed at the end of the required first interruption of the light curtain.
4	Muting failure (blocked LC)	1) The selected max. muting time had been exceeded (muting lamp on).
4	Muting failure (lamp)	2) The muting lamp is not connected between terminals 48 and M1 and M2. 3) The necessary bridge is not connected between terminal S41-S42.. 4) The muting lamp is defective. 5) The measuring circuit for the muting lamp is defective, the unit has to be repaired.
5	Stepping operation (key failure)	1) Both contacts of the key switch to select the number of steps are open

\*) No.: number of flash pulses in a series

### Status indication

run 1 and output 48 are flashing fast with 3 Hz	
Muting operation: Override possible	Minimum one muting sensor is active, LC 1 is interrupted and the start button is pressed. After 3 s with activated start button the override is started for max. 12 s.
Stepping operation: Wait for access	The unit is waiting for the required number of interruptions of the LC so that the safety relays can be activated.