

MINISTART
Smart Motorstarter
UG 9410



Product Description

The smart motorstarter UG 9410 can be used for softstart, softstop, reversing and protecting 3 phase asynchronous motors. By measuring the line current a thermal model is used to calculate the motor temperature, and in the case of overtemperature the motor is disconnected. In addition also a thermo switch can be used. The reversing is done via relays. The relays are switched without current flow, this provides long service life.

Your Advantages

- Widely used measuring and automation protocol
- Up to 7 functions in one device
 - Reversing anticlockwise,
 - Reversing clockwise
 - Softstart
 - Softstop
 - Motor protection
 - Phase sequence monitoring
 - Phase failure monitoring
- 80 % less space
- Simple and time-saving commissioning as well as user-friendly
- Operation through parameterization via modbus
- Hybrid relay combines benefits of relay technology with non-wearing semiconductor technology
- High availability by
 - Temperature monitoring of semiconductors
 - High withstand voltage up to 1500 V
 - Load free relay reversing function
 - Device overload
- Pluggable clamps
- TWIN- connection terminals to loop auxiliary supply and Bus

Features

- According to IEC/EN 60947-4-2
- Modbus RTU-interface
- To reverse 3 phase motors up to 0.18 kW ... 2.2 kW at 400 V
- 2-phase softstart, softstop
- 3 potentiometer for setting the modbus adress and baud rate
- 5 LEDs for status indication
- Reversing with relays without current, softstart, softstop with thyristor
- Galvanic separation between control circuit and power circuit
- Width: 22.5 mm

Function Diagram

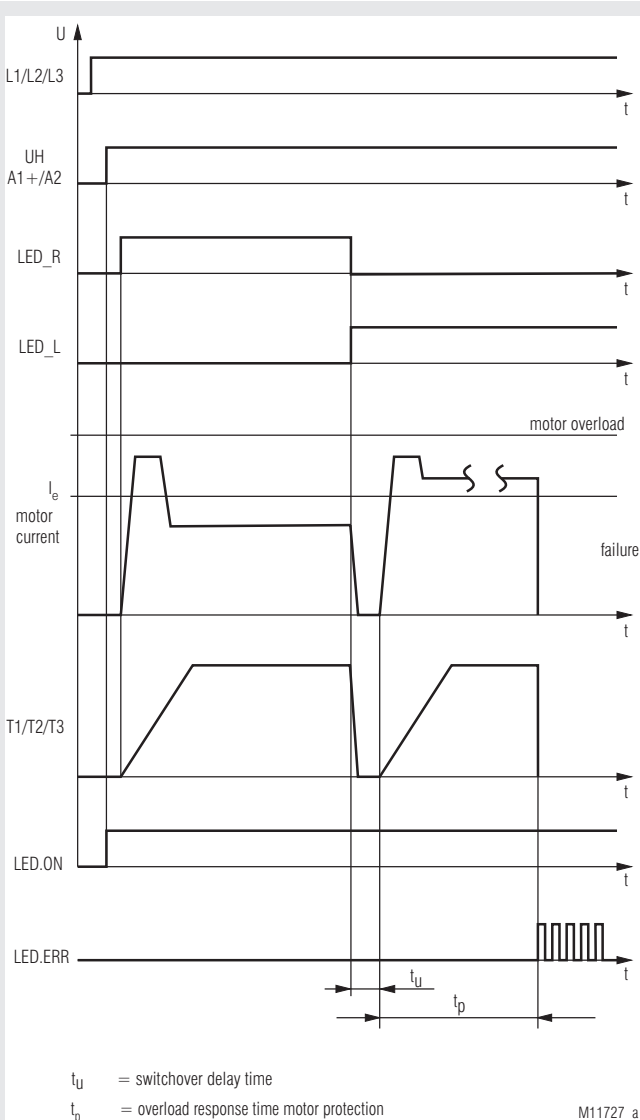

Approvals and Markings



Applications

- Reversing operation for door and gate controls, bridge drives and lifting applications
- Conveyor systems
- Actuating drives in process controls

Circuit Diagram

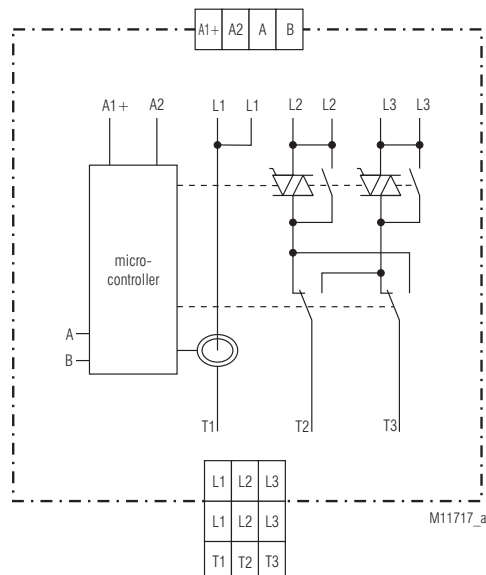

Connection Terminals

Terminal designation	Signal description
A1 (+)	Auxiliary voltage + DC 24 V
A2	Auxiliary voltage 0 V
A	Modbus signal A
B	Modbus signal B
L1	Phase voltage L1
L2	Phase voltage L2
L3	Phase voltage L3
T1	Motor connection T1
T2	Motor connection T2
T3	Motor connection T3

Function

Softstart

2 motor phases are controlled using thyristors, so that the motor current rises continuously. The starting torque behaves in the same way. This provides shock free starting and reduces mechanical failures. Starting time and starting voltage can be adjusted via Modbus.

Softstop

2 motor phases are controlled using thyristors, so that the motor current drops continuously. The motor torque behaves in the same way on run down. This provides shock free stopping and reduces mechanical failures. Stopping time and stopping voltage can be adjusted via Modbus.

Motor protection

The thermal load of the motor is calculated using a thermal model. The current is measured in phase T3. A symmetric current load of all 3 phases of the motor is assumed for flawless functioning. When the trigger value – stored in the trigger characteristics-, is reached, the motor is switched off and the device switches to fault 8.

The fault and motor leading can be acknowledged via Modbus.

Attention: The data of the thermal model is cleared through reset. In this case, the user must provide adequate cooling time of the motor resp. of the UG 9410.



Phase sequence detection

For correct function of the unit a clockwise phase sequence is required. The phase sequence monitoring feature checks on power up the sequence of the connected voltage and signals on anticlockwise sequence the fault 3. This fault can be cleared via Modbus.

Phase failure monitoring

After connecting the auxiliary supply, the unit checks if all 3 phases are correct. If one or more phases are missing, the unit indicates fault 4. This fault can be reset via Modbus.

Indicators

Green LED "On": Permanent on - Supply connected

Red LED "ERR": Flashing - Failure code of the device

Yellow LED "Bus": Flashing - When receiving or transmitting Modbus data

Yellow LED "L": Permanent on - Motor turns anti-clockwise
Flashing - Softstart or softstop active on anti-clockwise turn

Yellow LED "R": Permanent on - Motor turns clockwise
Flashing - Softstart or softstop active on clockwise turn

Failure code :

- 1 - Overtemperature on semiconductors
- 2 - Wrong mains frequency
- 3 - Phase reversal detected
- 4 - Phase failure detected
- 7 - Incorrect temperature measurement circuit
- 8 - Motor protection has responded
- 9 - Modbus communication failure
- 10 - Checksum failure EEPROM

1*) - 10*) = Number of flashing pulses in sequence

Reset Function

By sending a reset command a reset can be operated via Modbus

Modbus RTU

For communication between motor controller and a supervising control the Modbus RTU protocol according to Specification V 1.1b3 is used.

Setting

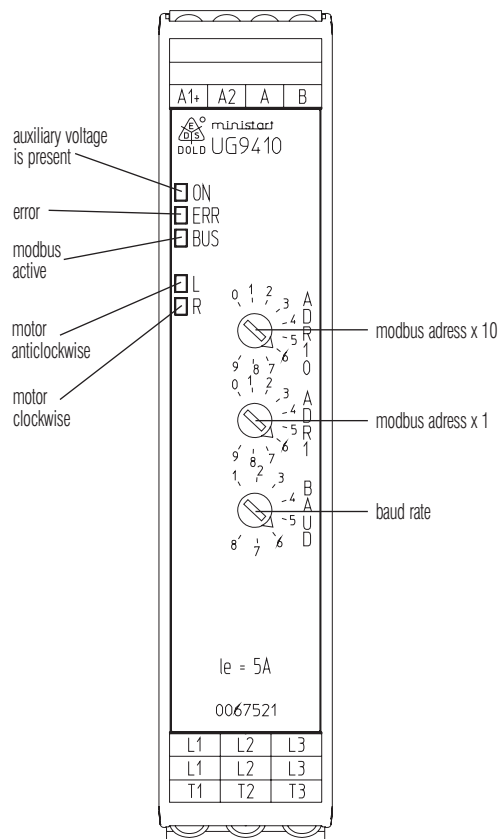

M11731_a

Position Potentiometer BAUD	1	2	3	4	5	6	7	8
Baud rate Baud	1200	2400	4800	9600	19200	38400	57600	115200
Response Time	< 50 ms	< 25 ms	< 12 ms	< 10 ms	< 5 ms	< 5 ms	< 5 ms	< 5 ms

Technical Data	
Nominal voltage L1/L2/L3:	3 AC 200 ... 480 V ± 10%
Nominal frequency:	50 / 60 Hz , automatic detection
Auxiliary voltage:	DC 24 V ± 10%
Motor power:	0.5 A ... 5.0 A adjustable via Modbus
Operating mode	
5.0 A:	AC 53a: 6-2: 100-30 IEC/EN 60947-4-2
Surge current:	200 A (tp = 20 ms)
Load limit integral:	0 ... 10 s adjustable via Modbus
Peak reverse voltage:	1500 V
Overvoltage limiting:	AC 510 V
Leakage current in off state:	< 3 x 0.5 mA
Start / deceleration voltage:	30 ... 80 % adjustable via Modbus
Start / deceleration ramp:	0 ... 10 s adjustable via Modbus
Consumption:	2 W
Switchover delay time:	150 ms
Start up delay for master tick:	Min. 25 ms
Release delay for master tick:	Min. 30 ms
Current measurement:	AC 0.5 ... 30 A
Measuring accuracy:	± 5% of end of scale value
Measured value update time	
at 50 Hz:	100 ms
at 60 Hz:	83 ms
Motor protection	
up to 5.0 A:	Class 10
Electronically, with thermal memory	
Reset:	Manual via Modbus
Short circuit strength	
max. fuse rating:	25 A gG / gL IEC/EN 60947-5-1
General Data	

Operating mode:	Continuous operation	
Operation:	0 ... + 65 °C (see derating curve)	
Storage:	- 40 ... + 70 °C	
Relative air humidity:	93 % at 40 °C	
Altitude:	< 1000 m	
Clearance and creepage distances		
rated impuls voltage / pollution degree		
Motor voltage- control voltage:	6 kV / 2	IEC 60664-1
Motor voltage- Modbus:	6 kV / 2	IEC 60664-1
Overvoltage category:	III	
EMC		
Electrostatic discharge:	8 kV (air)	IEC/EN 61000-4-2
HF-irradiation		
80 MHz ... 1.0 GHz:	10 V / m	IEC/EN 61000-4-3
1.0 GHz ... 2.5 GHz:	3 V / m	IEC/EN 61000-4-3
2.5 GHz ... 2.7 GHz:	1 V / m	IEC/EN 61000-4-3
Fast transients:	2 kV	IEC/EN 61000-4-4
Surge voltages between		
wires for power supply:	1 kV	IEC/EN 61000-4-5
between wire and ground:	2 kV	IEC/EN 61000-4-5
HF wire guided:	10 V	IEC/EN 61000-4-6
Voltage dips	IEC/EN 61000-4-11	
Interference emission		
Wire guided:	Limit value class B	IEC/EN 60947-4-2
Radio irradiation:	Limit value class B	IEC/EN 60947-4-2
Harmonics:	EN 61000-3-2	
Degree of protection:		
Housing:	IP 40	IEC/EN 60529
Terminals:	IP 20	IEC/EN 60529
Vibration resistance:	Amplitude 0,35 mm	
	Frequency 10 ... 55 Hz, IEC/EN 60068-2-6	
Climate resistance:	0 / 065 / 04 IEC/EN 60068-1	
Wire connection:	DIN 46228-1/-2/-3/-4	
Removable terminal blocks		
Wire connection		
Phase voltage and motor pluggable screw terminal (S):	0.25 ... 2.5 mm ² solid or 0.25 ... 2.5 mm ² stranded ferruled	
Wire connection:		
Bus and auxiliary supply pluggable Twin-cage-clamp-terminal (PT):	0.25 ... 1.5 mm ² solid or 0.25 ... 1.5 mm ² stranded ferruled	
Insulation of wires or sleeve length:	8 mm	
Fixing torque:	0.5 ... 0.6 Nm	

Technical Data		
Mounting:	DIN rail	IEC/EN 60715
Weight:	220 g	
Dimensions		
Width x height x depth:	22.5 x 105 x 120.3 mm	
Standard Type		
UG 9410PM	3 AC 200 ... 480 V	50/60 Hz 5.0 A
Article number:	0067521	
• Nominal voltage:	3 AC 200 ... 480 V	
• Nominal motor current:	5.0 A	
• Modbus RTU		
• Adjustable baud rate		
• Width:	22.5 mm	

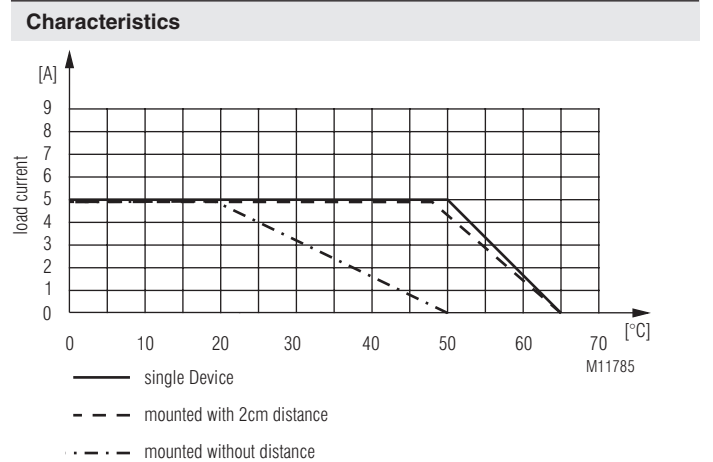

Derating curve:
Rated continuous current depending on ambient temperature and distance
Enclosure without ventilation slots

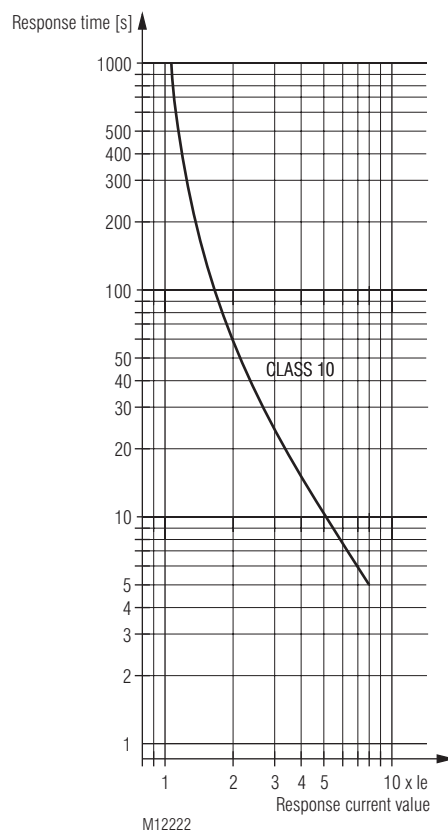

Trigger characteristics
Motor overload protection

Setting Facilities

- Potentiometer ADR10: - Unit adress x 10
 Potentiometer ADR1: - Unit adress x 1
 Potentiometer BAUD: - Baud rate

The module address and baud rate is only read after connecting the auxiliary supply!

Group fusing

Several motor starters can be wired in parallel on the supply side. Please make sure, that the total current cannot exceed 16 A. If several starters are use together and require more than 16 A, groups have to be split up for max 16 A.

Set-up Procedure

1. Connect motor and device according to application example. The 3 phases must be connected in correct sequence, wrong phase sequence will lead to failure (see failure code)
2. Setting unit adress and baud rate via potentiometer.
3. Power up the unit.
4. Parametrization via Modbus
5. At correct setting, the motor should ramp up continuously to full speed.

Safety Notes

- Never clear a fault when the device is switched on
- Attention:** This device can be started directly on the phase voltage without a contactor. Please be aware that the motor is still connected to the supply voltage also when it is not running. Therefore for work on motor and controller the supply has to be disconnected via E-stop.
- The user must ensure that the device and the necessary component are mounted and connected according to the locally applicable regulations and technical standards (VDE, TÜV,BG).
- Adjustments may only be carried out by qualified specialist staff and the applicable safety rules must be observed.
- Touch proof security is only provided when the power connection terminals are plugged into the unit.

Application Example

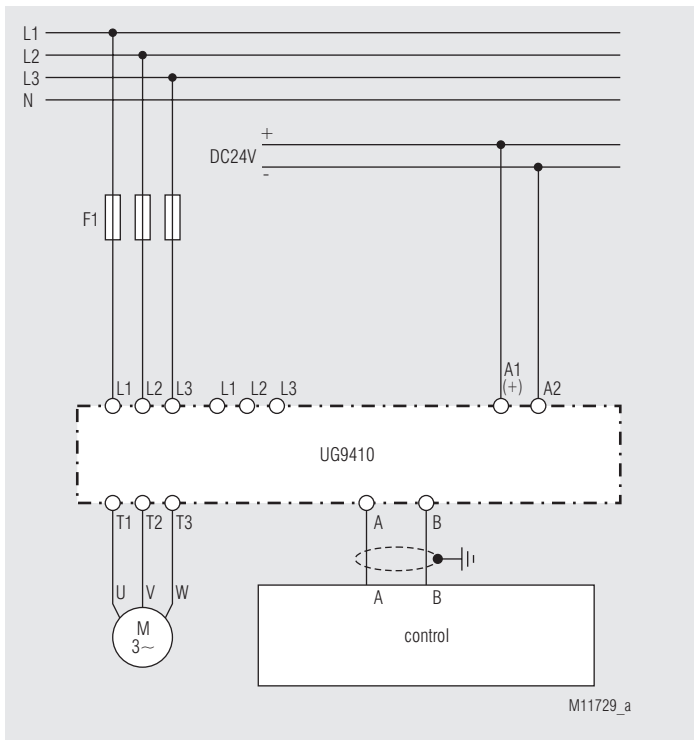

Motor control with UG 9410 and PLC via Modbus

Bus Interface

Protocol	Modbus Seriell RTU
Adress	1 bis 99
Baud rate	1200, 2400, 4800, 9600, 19200, 38400, 57600, 115200 Baud
Data bit	8
Stop bit	2
Parity	none

More information about the interface, wiring rules, device identification and communication monitoring can be found in the Modbus user manual.

Function-Codes

At UG 9410 the following function codes are implemented:

Function-Code	Name	Description
0x03	Read Holding Register	Device parameter read word by word
0x04	Read Input Register	Actual values read word by word
0x05	Write Single Coil	Outputs write individually
0x06	Write Single Register	Device parameter write word by word
0x10	Write Multiple Register	Device parameter write in blocks

Device configuration

If required the device configuration data can be saved permanently by setting the the Bit "WriteKonfig to EEPROM". The data is copied from the EEPROM to the relevant register when connecting the auxiliary voltage. As the numbers of write cycles of an EEPROM are limited, the writing must not be done in cycles. In addition it is not possible to receive modbus telegrams during a period of 50 ms while writing the EEPROM.

Parameter table

Every slave owns an output- configuration- and actual value table. In these tables it is defined under which address the parameters can be found.

Single Coils (Control signals):

Register-Adress	Protocol-Adresse	Name	Value range	Description	Data type	Access rights
1	0	RunRight	0x0000 0xFF00	Motor turns right off Motor turns right on	BIT	write
2	1	RunLeft	0x0000 0xFF00	Motor turns left off Motor turns left on	BIT	write
3	2	Reset	0x0000 0xFF00	No function Device reset	BIT	write
4	3	WriteKonfig to EEPROM	0x0000 0xFF00	No function Save parameter	BIT	write

Holding Register (Device configuration):

Register-Adress	Protocol-Adresse	Name	Value range	Description	Data type	Access rights
40001	0	Control word 1	0 ... 2	Bit 0 = Reset Bit 1 = WriteKonfig to EEPROM	UINT16	write / reading
40002	1	Control word 2	0 ... 2	Bit 0 = RunRight Bit 1 = RunLeft	UINT16	write / reading
40003	2	le *)	50 ... 500	Nominal motor current in 1/100 A	UINT16	write / reading
40004	3	Mon *)	30 ... 80	Softstart voltage in % from nominal voltage	UINT16	write / reading
40005	4	Ton *)	0 ... 100	Softstart ramp time in 1/10 Sec	UINT16	write / reading
40006	5	Moff *)	80 ... 30	Softstop voltage in % from nominal voltage	UINT16	write / reading
40007	6	Toff *)	0 ... 100	Softstop ramp time in 1/10 s	UINT16	write / reading
40008	7	Timeout release	0 ... 1	0 = Disable 1 = Enable	UINT16	write / reading
40009	8	Timeout	1000 ... 10000	Timeout value in ms	UINT16	write / reading

*) Parameters can be stored permanently in the EEPROM by setting the Bit "WriteKonfig to EEPROM"

Input Register (Device state and measuring values):

Register-Adress	Protocol-Adresse	Name	Value range	Description	Data type	Access rights
30001	0	State word 1 Device failure	0 ... 10	0: No failure 1: Overtemperature LT 2: Wrong frequency 3: Phase reversal 4: Phase failure 5: 6: 7: Temperatur circuit fault 8: Motor protection device actuated 9: Communication fault Modbus 10: Checksum failure EEPROM	UINT16	reading
30002	1	State word 2 State of device	0 ... 6	0: Device initialize 1: Wait for start 2: Softstart ramp 3: Clockwise On 4: Anti-clockwise On 5: Softstop ramp 6: Device in error mode	UINT16	reading
30003	2	Actual motor current	0 ... 3000	Actual motor current in 1/100 A	UINT16	reading
30004	3	Motor load	0 ... 100	Motor load in % from rated motor power	UINT16	reading

